

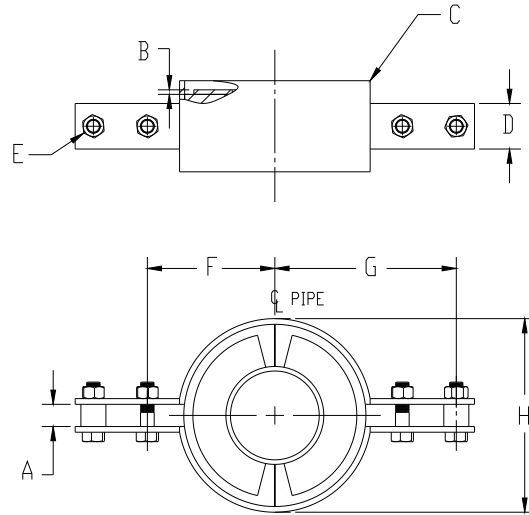

**MODEL E1000, MODEL E1010,
MODEL E1020, MODEL E1030**

**Insulated Pipe Riser Clamps
for Downward Loads**

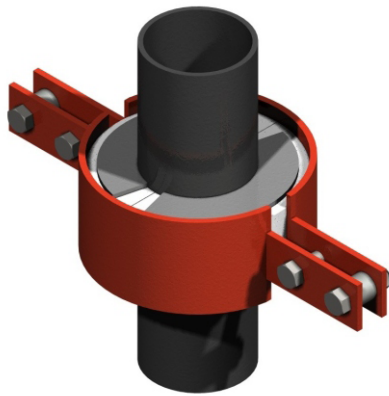

a. If thrust plate thickness "B" is greater than pipe wall thickness, consult factory.

b. One pair thrust plates supplied loose for field welding, top only.

Note: For higher load ratings, see: E1100

Pipe Size	Load lbs	A	B	C	D	E	Insul. Thk. = 1"			Insul. Thk. = 2"			Insul. Thk. = 3"			Insul. Thk. = 4"		
							F	G	H	F	G	H	F	G	H	F	G	H
							2	250	0.63	0.25	0.25 x 3.00	1.50	0.625	3.69	5.69	5.13	4.75	6.75
2 1/2	300	0.63	0.25	0.25 x 3.00	1.50	0.625	3.94	5.94	5.63	5.25	7.25	8.25	6.25	8.25	10.25	7.31	9.31	12.38
3	400	0.63	0.25	0.25 x 3.00	1.50	0.625	4.22	6.22	6.19	5.25	7.25	8.25	6.25	8.25	10.25	7.31	9.31	12.38
4	600	0.63	0.25	0.25 x 3.00	1.50	0.625	4.75	6.75	7.25	5.75	7.75	9.25	6.81	8.81	11.38	7.81	9.81	13.38
5	800	0.63	0.25	0.25 x 3.00	1.50	0.625	5.25	7.25	8.25	6.25	8.25	10.25	7.31	9.31	12.38	8.44	10.44	14.63
6	1000	0.63	0.25	0.25 x 4.00	2.00	0.625	5.75	7.75	9.25	6.81	8.81	11.38	7.81	9.81	13.38	8.94	10.94	15.63
8	1300	0.63	0.25	0.25 x 4.00	2.00	0.625	6.81	8.81	11.38	7.81	9.81	13.38	8.94	10.94	15.63	9.94	11.94	17.63
10	1600	0.63	0.38	0.38 x 5.00	3.00	0.625	8.06	10.31	13.63	9.19	11.44	15.88	10.19	12.44	17.88	11.19	13.44	19.88
12	1700	0.63	0.38	0.38 x 5.00	3.00	0.625	9.19	11.44	15.88	10.19	12.44	17.88	11.19	13.44	19.88	12.19	14.44	21.88
14	2000	0.88	0.38	0.38 x 5.00	3.00	0.625	9.69	11.94	16.88	10.69	12.94	18.88	11.69	13.94	20.88	12.69	14.94	22.88
16	2300	0.88	0.38	0.38 x 5.00	3.00	0.625	10.69	12.94	18.88	11.69	13.94	20.88	12.69	14.94	22.88	13.69	15.94	24.88
18	2500	0.88	0.38	0.38 x 5.00	3.00	0.625	11.69	13.94	20.88	12.69	14.94	22.88	13.69	15.94	24.88	14.69	16.94	26.88
20	2700	0.88	0.38	0.38 x 5.00	3.00	0.625	12.69	14.94	22.88	13.69	15.94	24.88	14.69	16.94	26.88	15.69	17.94	28.88
24	2800	0.88	0.38	0.38 x 5.00	3.00	0.625	14.69	17.19	26.88	15.69	18.19	28.88	16.69	19.19	30.88	17.69	20.19	32.88

Application:

Model E1 000 through E 1030 is designed for use on:

- Hot Water
- Vacuum
- Gas
- Cold Water
- Steam
- Air

· Dual Temperature

· Chilled Water

Intended for installation on:

· Vertical runs of insulated pipe with downward load only.

Other:

· For handling both upward and downward loads, see E 2000

Temperature Range:

+40°F to +650°F

Features:

- All pipe sizes
- Easy Installation
- Positive stop - axially downward
- May be supported from below or above
- Overlapping galvanized sheet metal jacket
- Insulating structural inserts for load transfer
- Other I.D.'s and/or O.D.'s Available on Request
- Eliminates condensation sweating on chilled water risers

Performance Test Results on File:

Available upon request

Material Data:

· E 1000 - E 1030: specification document: No. 206.

· Steel Top Thrust Plates:

Model ASTM For Pipe Material

E 1000 A36 Carbon-Steel

E 1010 A387G R.1 1 Chrome-Moly

E 1020 A515G R.7 0 Carbon Silicon

E 1030 A304L Stainless Steel

· Insulation: Calcium Silicate asbestos-free, treated with water repellent.

· Jackets: Galvanized Steel ASTM A-527.

· G glue: Industrial contact adhesive

· Structural Inserts: High-density calcium silicate asbestos free, treated with water repellent.

· Steel S traps/Base: Carbon Steel ASTM A-36.

· Fasteners: ASTM A-307 plate.

· Coating: Primer coated or hot dipped galvanized.

Other coatings available upon request.

Formal Submission Sheets available.