

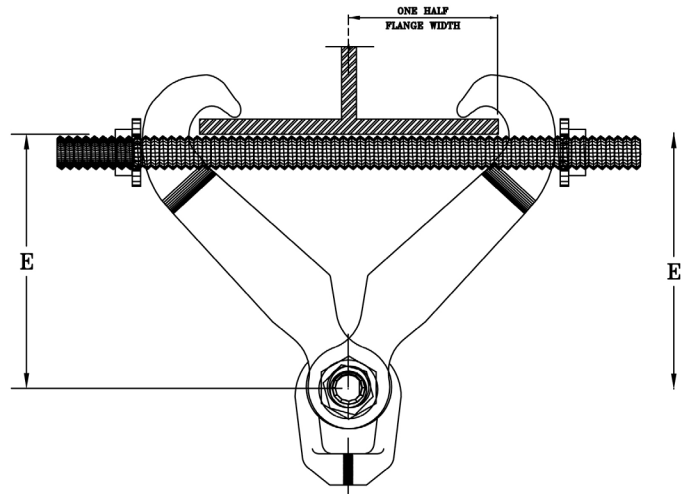

FIG. 135

MALLEABLE BEAM CLAMP

www.pipingtech.com/fig135

- MATERIAL:** Malleable iron
- FINISH:** Black
- SERVICE:** Recommended for attachment to structural steel. Use in conjunction with American Standard I-Beams and wide flange beams where beam widths are from a min. of 2 3/8" to a max. of 7" and flange thickness does not exceed 0.60".
- ORDERING:** Specify figure number and description.



MAXIMUM ROD SIZE	BOLT DIA.	ROD TAKE OUT (E) - FOR WIDTH OF BEAM FLANGE						MAX. RECOM. LOAD (lb.)	APPROX. WEIGHT (lb. per each)
		2 3/8	3	4	5	6	7		
7/8	7/16	3 1/2	3 7/16	3 5/16	2 15/16	2 9/16	1 7/8	1,365	2.2

SCOMPONENTS03.XLS-07/01/09

FIG. 140

HEAVY DUTY BEAM CLAMP

www.pipingtech.com/fig140

- MATERIAL:** Carbon steel
- FINISH:** Painted, shop primed or galvanized.
- SERVICE:** For suspension of heavy loads from standard I-Beams and wide flange beams with flange widths to 15" and flange thickness to 1.07".
- ORDERING:** Specify rod size, figure number, description, clamp size, beam size and finish.

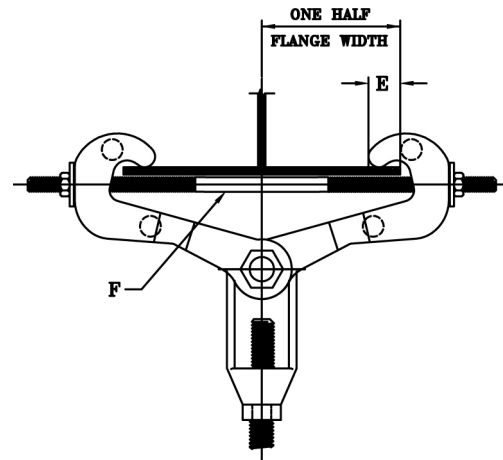

CLAMP SIZE	E	F	MAX. LOAD (lb.)	APPROX. WEIGHT (lb. per each)	MAXIMUM FLANGE	
					THK.	WIDTH
1	1	0.375	11,500	9	1.07	10
2	1	0.375	11,500	11	1.07	15

SCOMPONENTS03.XLS-07/01/09

SUPPORT ASSEMBLY COMPONENTS