



FIG. 300

T-BAR CRADLE SUPPORT WITH GUIDE & SLIDE PLATES CRADLED GUIDED SUPPORT

www.pipingtech.com/fig300

- MATERIAL:** Carbon steel
- FINISH:** Painted or hot dipped galvanized.
- OPTIONS:** Modifications in the dimensions A, C, D, F, and the slide plate material (PTFE, 25% glass filled or graphite) available upon request.
- ORDERING:** Specify pipe size, figure number, description, type, quantity, finish and slide plate material.
- ALLOWABLE LOADS:** The allowable vertical loads depend upon the pipe pressure and wall thickness.
- BONDING:** Graphite slide plates are usually bonded. For high temperature service above 500 °F specify bolted construction.
- NOTE:**
- Optional bolted base plate, specify Fig. 301.
 - For upper graphite slide material to be of bolted design, specify Fig. 300-B or Fig. 301-B (see below).

 **FIG. 300 - WELDED BASE**

 **FIG. 301 - BOLTED BASE**

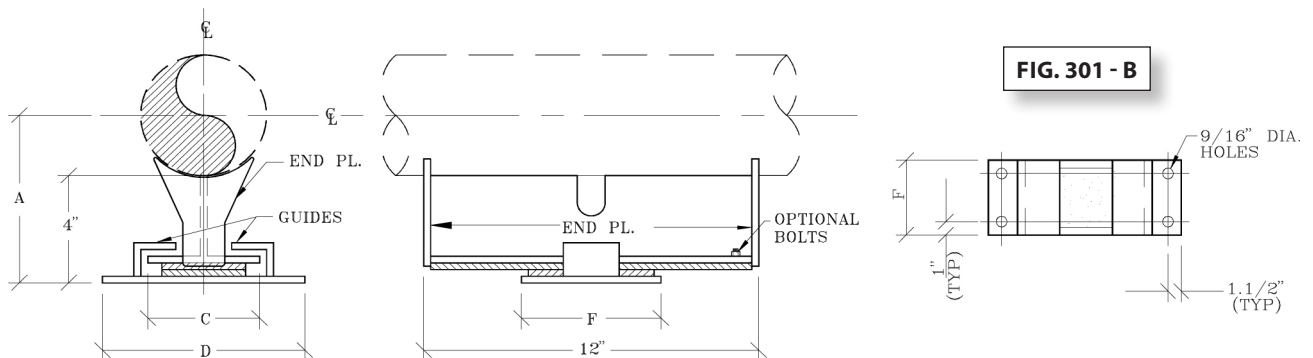

PIPE SIZE	A	C	D	F	APPROX. WEIGHT (lb. per each)
2	5 3/16	4	7 1/4	5	16.3
3	5 3/4	4	7 1/4	5	16.3
4	6 1/4	4	7 1/4	5	16.3
6	7 5/16	4	7 1/4	5	17.6
8	8 5/16	4	7 1/4	5	18.2
10	9 3/8	4	7 1/4	5	19.0
12	10 3/8	4	7 1/4	5	19.7
14	11	4	7 1/4	5	23.0
16	12	4	7 1/4	5	24.0
18	13	7	10 3/4	5 1/2	39.0
20	14	7	10 3/4	5 1/2	40.0
24	16	7	11 1/4	5 1/2	42.0

PIPESH0ES01.XLS-07/17/09