

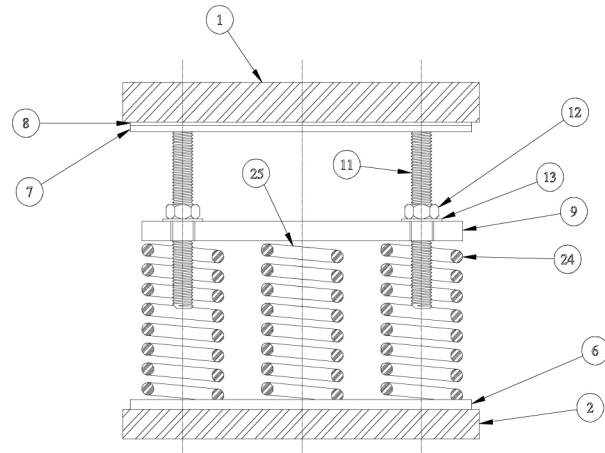
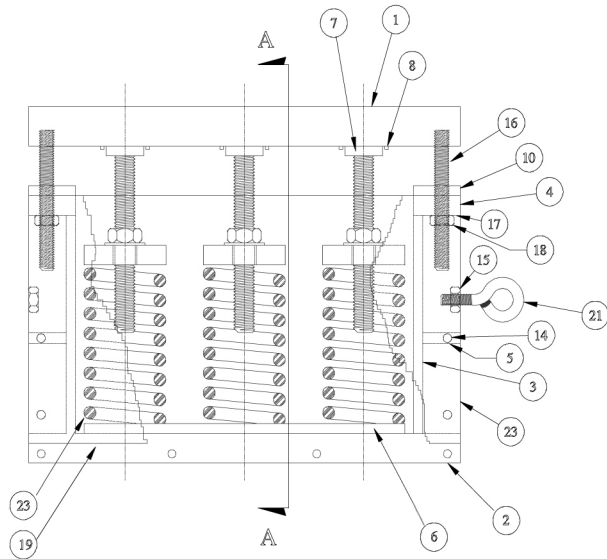

FIG. 500

BIG TON SPRING SUPPORT

ENGINEERED SPRING SUPPORTS

www.pipingtech.com/fig500



BIG TON SPRING SUPPORT ASSEMBLY DRAWING

NOTES:

1. Paint shims red, Item 10 remove in field.
2. Field to remove lifting eye-bolts Item 21.
3. Shipping Wt. = (lb.)

SPECIFICATIONS:

1. Design Load = (lb.)
2. Deflection: Up = (in.)
Down = (in.)
3. Spring Rate = (lb./in.)
4. Shipping Wt. = (lb.)

ORDERING:

Specify spring rate, figure number, description, design load and travel.

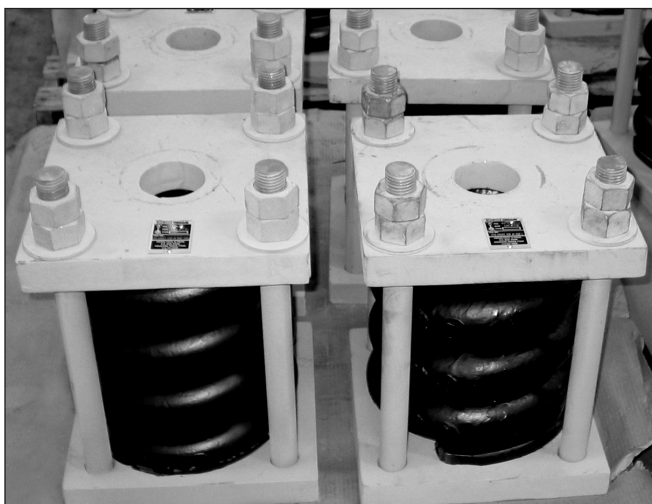

45,000 LB. LOAD BOILER SPRING ASSEMBLIES FOR A POWER PLANT

MATERIAL ITEMS

ITEM NO.	QTY.	DESCRIPTION
1	1	TOP LOAD FLANGE
2	1	BOTTOM FLANGE
3	2	SIDE PLATE
4	2	SIDE PLATE TOP BAR
5	2	SIDE PLATE BTM. BAR
6	1	SPRING BTM. SUPPORT PLATE
7	3	STUD PRESSURE PLATE
8	6	PRESSURE PLATE GUIDE BARS
9	3	SPRING PRESSURE PLATE
10	4	SHIM PLATES
11	6	LOAD STUDS
12	6	LOAD STUD NUTS
13	6	LOAD STUD WASHERS
14	12	COVER PLATE BOLTS
15	4	LIFTING NUTS
16	8	LIMIT STOP STUDS
17	8	LIMIT STOP WASHERS
18	8	LIMIT STOP NUTS
19	2	COVER PLATES
20	2	COVER PLATE GASKET
21	4	LIFTING EYE BOLTS
22	1	NAME PLATE
23	4	SIDE PLATE VERTICAL BARS
24	9	OUTER SPRING
25	-	INNER SPRING (AS REQ'D)

SPRING.XLS-07/01/09