



FIG. 500

DOUBLE T-BAR CRADLE SUPPORT WITH BONDED/BOLTED SLIDE PLATE CRADLED NON-GUIDED SUPPORT

www.pipingtech.com/fig500

- MATERIAL:** Carbon steel
- FINISH:** Painted or hot dipped galvanized.
- OPTIONS:** Modifications in the dimensions A, B, C, D, and the slide plate material (PTFE, 25% glass filled or graphite) available upon request.
- ORDERING:** Specify pipe size, figure number, description, type, quantity, finish and slide plate material.
- ALLOWABLE LOADS:** The allowable vertical loads depend upon the pipe pressure and wall thickness.
- NOTE:**
- Optional bolted base plate, specify Fig. 501.
 - For upper graphite slide material to be of bolted design, specify Fig. 500-B or Fig. 501-B (see below).

FIG. 500 - WELDED BASE

FIG. 501 - BOLTED BASE

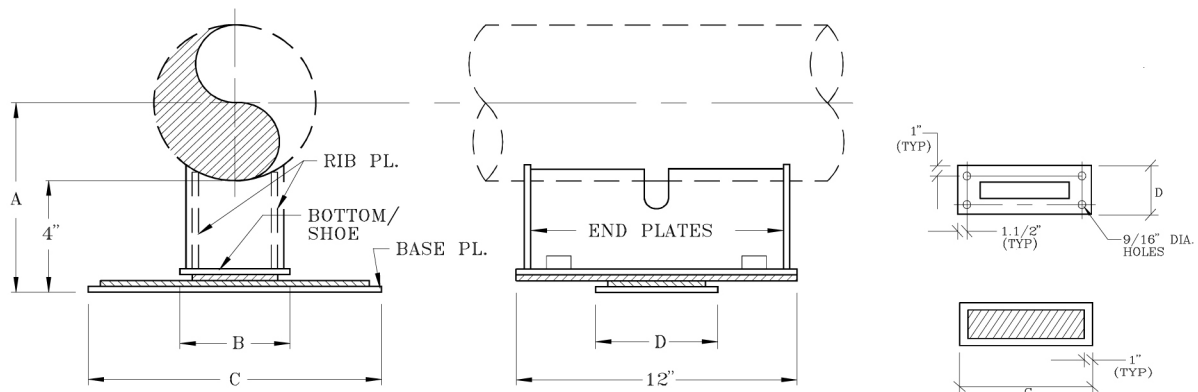

PIPE SIZE	A	B	C	D	APPROX. WEIGHT (lb. per each)
6	7 5/16	4	12	5	17.0
8	8 5/16	5 1/2	12	5	25.0
10	9 3/8	6 1/2	18	5	29.0
12	10 3/8	7 1/2	18	5	31.0
14	11	8 1/2	18	5	32.0
16	12	10	18	5	33.0
18	13	11	21	5 1/2	45.0
20	14	12	21	5 1/2	47.0
24	16	14 1/4	24	5 1/2	65.0
30	19	17 1/2	28	5 1/2	87.0
36	22	20 1/2	30	5 1/2	97.0
42	25	23 1/2	36	5 1/2	112.0

PIPESH0ES01.XLS-09/19/09