



FIG. 700

U-BOLT CRADLE SUPPORT WITH BONDED/BOLTED SLIDE PLATE CRADLED NON-GUIDED SUPPORT

www.pipingtech.com/fig700

- MATERIAL:** Carbon steel
- FINISH:** Painted or hot dipped galvanized.
- OPTIONS:** Modifications in the dimensions A, B, C, D, and the slide plate material (PTFE, 25% glass filled or graphite) available upon request.
- ORDERING:** Specify pipe size, figure number, description, type, quantity, finish and slide plate material.
- ALLOWABLE LOADS:** The allowable vertical loads depend upon the pipe pressure and wall thickness.
- BONDING:** Graphite slide plates are usually bonded. For high temperature service above 500 °F specify bolted construction.
- NOTE:**
- Optional bolted base plate, specify Fig. 701.
 - For upper graphite slide material to be of bolted design, specify Fig. 700-B or Fig. 701-B (see below).

FIG. 700 - WELDED BASE

FIG. 701 - BOLTED BASE

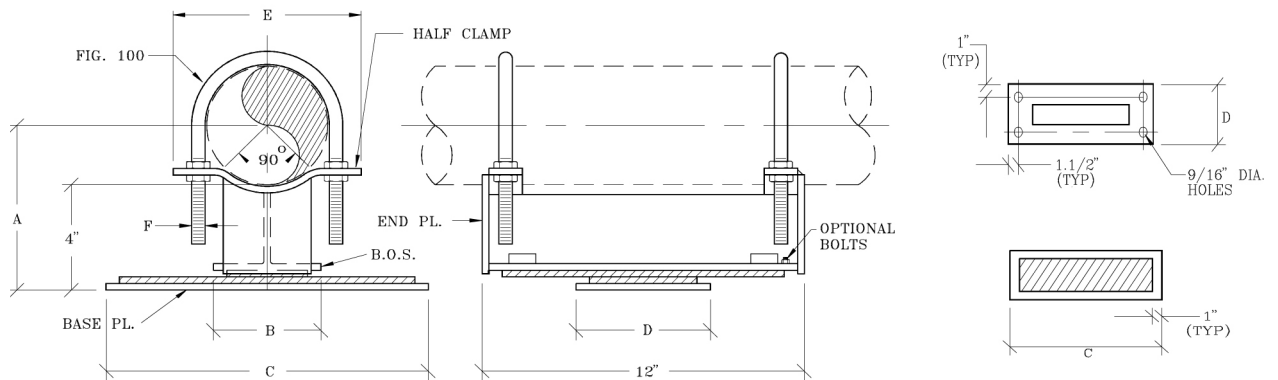

PIPE SIZE	A	B	C	D	E	F	APPROX. WEIGHT (lb. per each)
2	5 3/16	4	12	5	4	3/8	14.0
3	5 3/4	4	12	5	5 1/2	1/2	14.0
4	6 1/4	4	12	5	6 1/2	1/2	15.0
6	7 5/16	4	12	5	9 1/8	5/8	22.0
8	8 5/16	4	12	5	11 1/4	5/8	25.0
10	9 3/8	4	12	5	14	3/4	31.0
12	10 3/8	4	12	5	16 3/4	7/8	39.0
14	11	4	12	5	18	7/8	46.0
16	12	4	12	5	19 3/4	7/8	49.0
18	13	7	15	5 1/2	22	1	66.0
20	14	7	15	5 1/2	24	1	70.0
24	16	7	15	5 1/2	28	1	78.0

PIPESH0ES01.XLS-07/17/09