



## FIG. 89

## CLEVIS HANGER FOR INSULATED LINES

[www.pipingtech.com/fig89](http://www.pipingtech.com/fig89)

- MATERIAL:** Carbon steel
- FINISH:** Black
- FUNCTION:** Equivalent to Fig. 83, except bottom has been lengthened to allow covering without interfering with the bolt.
- APPROVALS:** Conforms to Federal Specification WW-H-171-E, Type 1 and Manufacturers Standardization Society SP-69, Type 1
- COMPONENTS:** Top yoke, bottom strap, and bolt or stud with nut-assembled.
- ORDERING:** Specify pipe size, figure number, description and finish.

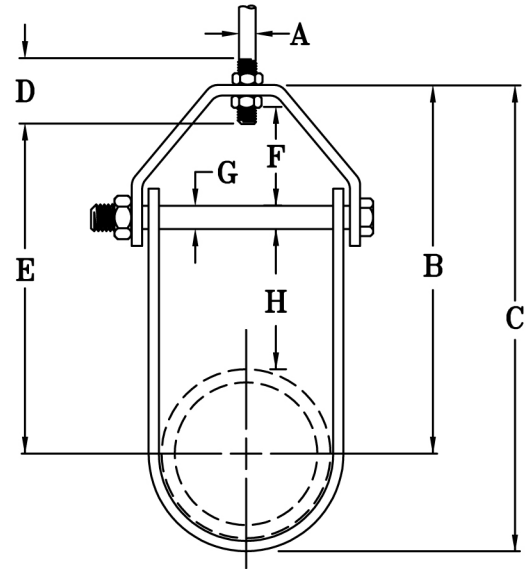

PIPE SIZE	MAX. RECOM. LOAD (lb.)	APPROX. WEIGHT (lb. per 100)	SIZE OF STEEL		A	B	C	D	E	ADJUST.		
			UPPER	LOWER						F	G	H
1/2	730	44	1/8 x 1	1/8 x 1	3/8	3 5/8	4 3/16	2 1/2	2 7/8	1/2	1/4	2
3/4	730	51	1/8 x 1	1/8 x 1	3/8	3 5/8	4 1/4	2 1/2	2 7/8	1/2	1/4	2
1	730	58	1/8 x 1	1/8 x 1	3/8	4	4 11/16	2 1/2	3 1/4	5/8	1/4	2
1 1/4	730	64	1/8 x 1	1/8 x 1	3/8	4 7/16	5 1/4	2 1/2	3 5/8	7/8	1/4	2
1 1/2	730	72	1/8 x 1	1/8 x 1	3/8	4 3/4	5 3/4	2 1/2	4 1/16	1 1/16	1/4	2
2	730	85	1/8 x 1	1/8 x 1	3/8	7 7/16	8 11/16	2 1/2	6 1/2	1 5/8	1/4	4
2 1/2	1,350	191	3/16 x 1 1/4	3/16 x 1 1/4	1/2	8 7/16	9 15/16	3	7 1/2	2	3/8	4
3	1,350	201	3/16 x 1 1/4	3/16 x 1 1/4	1/2	8 5/8	10 5/16	3	7 9/16	1 3/4	3/8	4
3 1/2	1,350	210	3/16 x 1 1/4	3/16 x 1 1/4	1/2	8 11/16	10 3/4	3	7 3/4	1 3/4	3/8	4
4	1,430	247	1/4 x 1 1/4	3/16 x 1 1/4	5/8	9 3/8	11 5/8	3 1/2	8 3/16	1 15/16	3/8	4
5	1,430	309	1/4 x 1 1/4	3/16 x 1 1/4	5/8	9 7/8	12 5/8	3 1/2	8 3/4	1 3/4	1/2	4
6	1,940	337	1/4 x 1 1/2	3/16 x 1 1/2	3/4	10 5/8	14	4	9 3/8	1 7/8	1/2	4
8	2,000	673	1/4 x 1 3/4	3/16 x 1 3/4	7/8	12 3/8	16 3/4	4 1/4	11	2	5/8	4
10	3,600	1,102	3/8 x 1 3/4	1/4 x 1 3/4	7/8	13 3/4	19 3/16	4 1/2	12 1/4	2 1/8	3/4	4
12	3,800	1,382	3/8 x 2	1/4 x 2	7/8	15 1/8	21 9/16	4 1/2	13 5/8	2 7/16	3/4	4

SCOMPONENTS02.XLS-07/01/09