

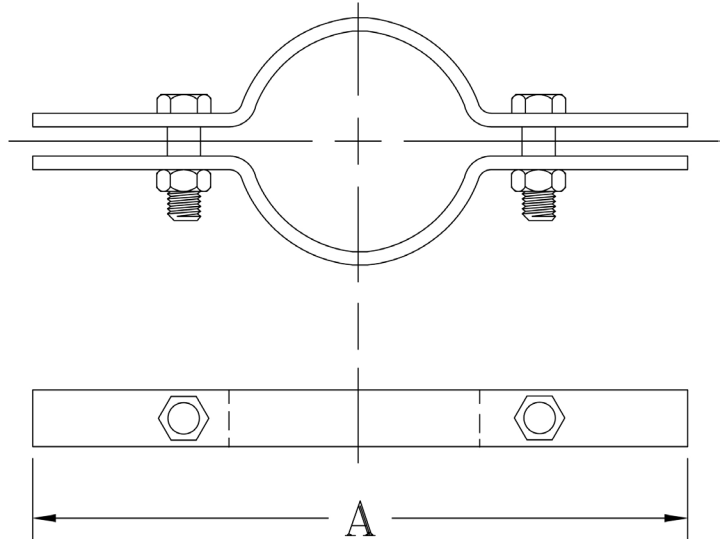

FIG. 90

RISER CLAMP

www.pipingtech.com/fig90

- SIZE RANGE:** ½" thru 24"
- MATERIAL:** Carbon steel
- FINISH:** Black or galvanized; furnished black unless otherwise specified.
- SERVICE:** For support and steadying of steel pipe risers either insulated or bare, cast iron pipe, or conduit.
- MAX. TEMP.:** 650 °F
- ORDERING:** Specify pipe size, figure number, description and finish.



SUPPORT ASSEMBLY COMPONENTS

PIPE SIZE	MAX. RECOM. LOAD (lb.)	APPROX. WEIGHT (lb. per 100)	LENGTH A	STOCK SIZE	BOLT SIZE
1/2	255	123	9 3/8	3/16 x 1 1/4	3/8 x 1 1/2
3/4	255	136	9 3/8	3/16 x 1 1/4	3/8 x 1 1/2
1	255	138	9 5/8	3/16 x 1 1/4	3/8 x 1 1/2
1 1/4	390	195	10	1/4 x 1 1/4	3/8 x 1 1/2
1 1/2	390	201	10 3/8	1/4 x 1 1/4	3/8 x 1 1/2
2	390	217	10 3/4	1/4 x 1 1/4	7/16 x 2
2 1/2	390	229	11 1/4	1/4 x 1 1/4	7/16 x 2
3	530	250	12	1/4 x 1 1/4	7/16 x 2
3 1/2	670	330	13	1/4 x 1 1/2	1/2 x 2
4	810	342	13 1/2	1/4 x 1 1/2	1/2 x 2
5	1,160	493	14 1/2	1/4 x 2	1/2 x 2
6	1,570	526	15 1/2	1/4 x 2	1/2 x 2
8	2,500	986	18 1/2	3/8 x 2	5/8 x 2 1/2
10	2,500	1,112	20 3/4	3/8 x 2	5/8 x 2 1/2
12	2,700	1,662	22 3/4	1/2 x 2	5/8 x 3
14	2,700	1,925	24	1/2 x 2	5/8 x 3
16	2,900	3,250	26	5/8 x 2 1/2	3/4 x 3 1/2
18	2,900	3,375	28	5/8 x 2 1/2	3/4 x 3 1/2
20	2,900	3,500	30	5/8 x 2 1/2	3/4 x 3 1/2
24	3,200	5,070	36	5/8 x 3	7/8 x 3 1/2

SCOMPONENTS01.XLS-07/01/09