



## FIG. 900

## BOLT CRADLE SUPPORT WITH BONDED/BOLTED SLIDE PLATE CRADLED NON-GUIDED SUPPORT

[www.pipingtech.com/fig900](http://www.pipingtech.com/fig900)

- MATERIAL:** Carbon steel
- FINISH:** Painted or hot dipped galvanized.
- OPTIONS:** Modifications in the dimensions A, B, C, D, and the slide plate material (PTFE, 25% glass filled or graphite) available upon request.
- ORDERING:** Specify pipe size, figure number, description, type, quantity, finish and slide plate material.
- ALLOWABLE LOADS:** The allowable vertical loads depend upon the pipe pressure and wall thickness.
- BONDING:** Graphite slide plates are usually bonded. For high temperature service above 500 °F specify bolted construction.

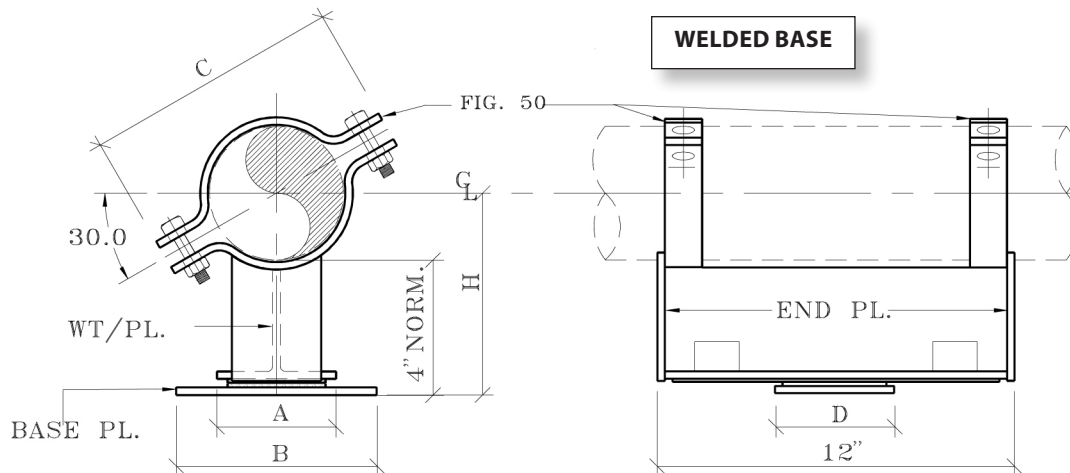

PIPE SIZE	A	B	C	D	H
2	4	12	5 1/2	5	5 3/16
2 1/2	4	12	6 3/8	5	5 7/16
3	4	12	7	5	5 3/4
4	4	12	8 9/16	5	6 1/4
5	4	12	9 11/16	5	6 13/16
6	4	12	11 5/8	5	7 5/16
8	4	12	13 7/8	5	8 5/16
10	4	12	17	5	9 3/8
12	4	12	18 15/16	5	10 3/8
14	4	12	21	5	11
16	4	12	23	5	12
18	7	15	25 7/8	5 1/2	13
20	7	15	28	5 1/2	14
24	7	15	33 1/2	5 1/2	16

PIPESH0ES01.XLS-07/17/09