



PTP HD-2

HOLD DOWN (LATERAL RESTRAINT)

www.pipingtech.com/ptp-hd2

MATERIAL: Carbon steel

FINISH: Black or galvanized.

TEMP.: 400 °F

APPLICATION: Fig. PTP HD-2 is a restraint type hold down. The clamp radius as well as the base is lined with PT&P's PTFE, 25% glass filled, slide plate, allowing axial movement while restraining lateral movement. It is generally used on compressor lines where temperature is high and thermal movement is great.

ORDERING: Specify pipe size, figure number and description.

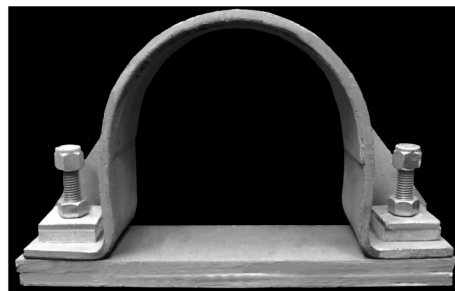

FOR PIPE SIZES 6 - 12 INCLUSIVE

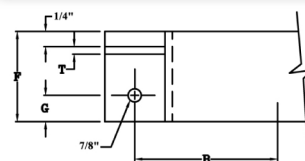

FOR PIPE SIZES 2 - 4 INCLUSIVE

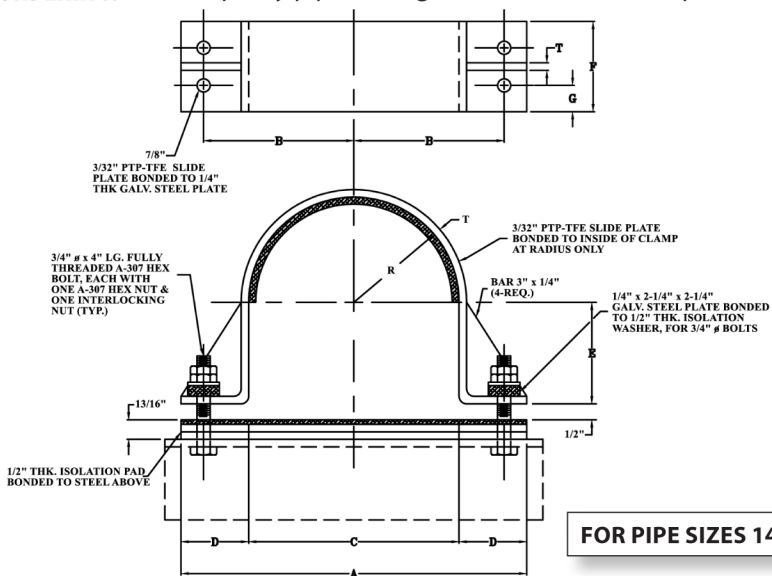
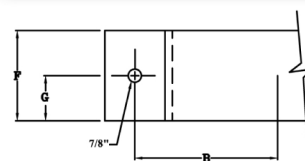

FOR PIPE SIZES 14 - 36 INCLUSIVE

PIPE SIZE	A	B	C	D	E	F	G	R	T
2	9 5/8	3 9/16	2 1/2	3 9/16	3/4	2 1/2	1 1/4	1 1/4	1/4
3	10 3/4	4 1/8	3 5/8	3 9/16	1 5/16	2 1/2	1 1/4	1 13/16	1/4
4	11 3/4	4 5/8	4 5/8	3 9/16	1 13/16	2 1/2	1 1/4	2 5/16	1/4
6	14 1/2	6	6 3/4	3 7/8	2 7/8	4	1 1/4	3 3/8	3/8
8	16 1/2	6 5/8	8 3/4	3 7/8	3 7/8	4	1 1/4	4 3/8	3/8
10	18 5/8	8 1/16	10 7/8	3 7/8	4 15/16	4	1 1/4	5 7/16	3/8
12	21 3/4	9 5/8	12 7/8	4 7/16	5 15/16	4	1 1/4	6 7/16	1/2
14	23	10 1/4	14 1/8	4 7/16	6 9/16	6	1 3/8	7 1/16	1/2
16	25	11 1/4	16 1/8	4 7/16	7 9/16	6	1 3/8	8 1/16	1/2
18	27	12 1/4	18 1/8	4 7/16	8 9/16	6	1 3/8	9 1/16	1/2
20	29	13 1/4	20 1/8	4 7/16	9 9/16	6	1 3/8	10 1/16	1/2
24	33	15 1/4	24 1/8	4 7/16	11 9/16	6	1 3/8	12 1/16	1/2
30	39	18 1/4	30 1/8	4 7/16	14 9/16	6	1 3/8	15 1/16	1/2
36	45	21 1/4	36 1/8	4 7/16	17 9/16	6	1 3/8	18 1/16	1/2

SCOMPONENTS06.XLS-12/29/09